

Circular rotational field in dielectromagnetic

Abstract. In article example of dielectromagnetics cores working in circular rotational magnetic fields of electric converters are presented. The main advantage of dielectromagnetics can be naturally isotropy of magnetic cores but, in some solutions, profitable can be artificially prepared anisotropy properties. The characteristic with distribution of magnetic circular rotating field in dielectromagnetic made without additional anisotropy process is shown. The obtained measurement results of distribution of magnetic circular rotating field confirm the natural isotropy of dielectromagnetic.

Streszczenie. Przedstawiono przykłady magnetowodów pracujących w wirujących kołowych polach magnetycznych wykonanych z dielektromagnetyków. Główną zaletą dielektromagnetyków może być ich naturalna izotropia; natomiast w niektórych przypadkach może być wykorzystana sztucznie wytworzona anizotropia magnetowodu. Wyniki pomiarów właściwości magnetycznych dielektromagnetyku potwierdziły ich naturalną izotropię - **Wirujące pole kołowe w dielektromagnetyku**

Keywords: composite's soft magnetic cores, dielectromagnetics, isotropy, circular rotational field

Słowa kluczowe: magnetycznie miękkie magnetowody kompozytowe, dielektromagnetyki, izotropia, wirujące pole kołowe

Introduction

Application the powder metallurgy technology for magnetic cores of electric machines allows a much broader spectrum solution's than made them by the commonly used electrical sheets.

Optimal form of the magnetic core may be difficult or even impossible to implement it in the form of magnetic core made of electrical sheets [1]. In these causes the main advantages of dielectromagnetics cores can be obtained. This core may have any shape dependent on the flow of the magnetic flux. Additionally it can be anisotropic or isotropic (requires the use of special processes) for the flowing stream. It's a main advantage of these materials. Magnetic cores for induction motors of low power [2] or linear motors can be an example. The great advantage of the composite materials are also low cost of their preparation due include of waste-free production.

Depending on the used technology we can obtain different from the viewpoint of magnetic and mechanical properties types of powder composites. Powder composites for soft magnetic cores can be divided into two basic groups:

- dielectromagnetics - composites derived from the molding consisting of soft magnetic powder and an organic or inorganic dielectric used for insulating and binding of the powder particles during the curing process at medium temperatures (180°C to 500°C), and
- sinters - composites prepared from powder compacts made of a soft magnetic powder by sintering it at high temperatures of the order of 1200°C, usually in protective atmospheres.

Dielectromagnetics compared to the sinters, are the powder composites characterized by favourable, smaller loss, particularly eddy current loss and a much simpler technology. Important is the lack of technological cramps on dielectromagnetics contractions occurring in sinter's technology. This avoids carrying out additional, final machining, practically necessary for the cores made of sinters. These features make the dielectromagnetics are of particular interest to scholars who saw a large application potential in these materials [2, 3].

Dielectromagnetics are becoming more widely used. It is the reason why global producers of iron powders are suppliers of different, specially prepared doped powder components for directly made soft magnetic dielectromagnetics. They contain selected fractions of iron powder, lubricants to facilitate the pressing process and a very important component responsible for the isolation and

gluing of components in the process of curing - binder. Usually it's epoxy resin. Kind of dielectric is very important because the curing temperature depends on it. This curing temperature cannot destroyed insulating properties, but on the other side, higher temperature is better to removal of internal stress in core, to improve their magnetic properties. The result of the isolation of the individual iron particles by covering their used dielectric is a significant increase the resistivity causes the reduction of eddy currents and, as a result, losses associated with them.

The condition of the optimal produce of magnetic cores is possibility to modify the properties of the dielectromagnetics, especially in the initial stage of their preparation.

Currently mechanical properties of dielectromagnetics are practically sufficient to perform small magnetic cores or parts of larger magnetic cores. Restrictions on the wider application are related to their magnetic properties, particularly in the variable (AC) magnetic field. Unfortunately, they are significantly inferior to those of electrical sheets [1].

Dielectromagnetics cores in rotational magnetic fields

Magnetic cores of dielectromagnetic are, for now by assumption, isotropic. It is the main advantage of magnetic cores made of them. But possible and appropriate, however, is also the production of anisotropic magnetic cores. Examples are cores made of different kind of parts. They are integrated cores. When they are more complicated configurations of their components they are also called hybrid cores. This magnetic cores can find use in various kind of electrical machines, both dc and ac machines (asynchronous and synchronous machines, stepping motors).

It may be desirable, for example, increase the conductivity of the part of magnetic core. In asynchronous machines integrated cores can lead not only magnetic flux (magnetically soft skeleton of the core) but electric current as well (conductive outside infiltrated layer) [2]. Figure 1 show the stator of the asynchronous motor with a rotor made of dielectromagnetic. The outer layer of this magnetic core has been infiltrated with copper and tin powder (40%Fe+30%Cu+30%Sn). Used the internal infiltration, wherein the conductive copper and tin powders were introduced to a part of the magnetic core at the stage of making a mixture of components: iron powder, conductive powder and additives necessary during the manufacturing process: a dielectric, lubricants, etc. This allows produce a

complete magnetic integrated core during the single pressing.



Fig. 1. The stator of the asynchronous motor with rotor made of infiltrated integrated core

As a result of the conducted infiltration of dielectromagnetics core resistivity was reduced from $50,5 [\mu\Omega\cdot m]$ to $0,2 [\mu\Omega\cdot m]$ in the infiltrated part. This made it possible to significantly increase the starting torque of the induction motor with dielectromagnetic core. Figure 2 show the motor starting torque with sheeted factory rotor and with rotor made of infiltrated integrated dielectromagnetic.

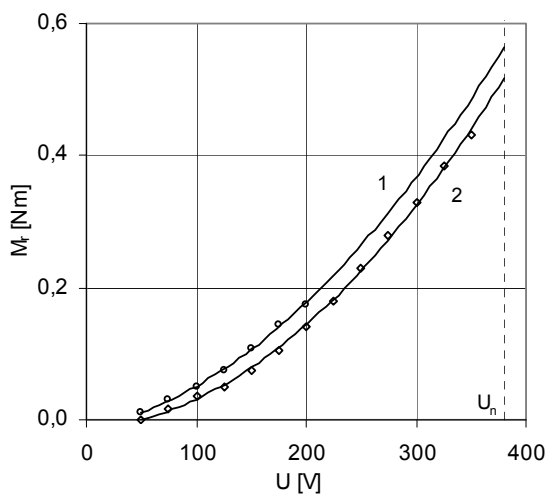

Fig. 2. The starting torque of the asynchronous motor with rotor made of infiltrated integrated dielectromagnetic (1) and sheeted cage factory rotor (2)

In small power electrical machines permanent magnets can be used for generate the magnetic flux. This is due to the increasing magnets quality and decreasing their price. The magnets are mainly made as an alloys or sinters of suitable metals. Hard magnetic powder composites can be made as well. The type of powder composite depends on quantity of used dielectric: in dielectromagnets up to 2%, in magneto-dielectrics above 2% of dielectric. These composites can be used for integrated (hybrid) cores thanks of technological uniformity with dielectromagnetics: soft magnetic component can be basic in both of them. On the Figure 3 presents two type integrated samples (a, b) and their possible practical applications - elements of stator electric machine's core induced by permanent magnets (c, d). It is two possible realizations: poles with pole shoes

(c), being source of steady magnetic flux in air gap of machine, as also with part of a stator yoke of machine (d) [4].

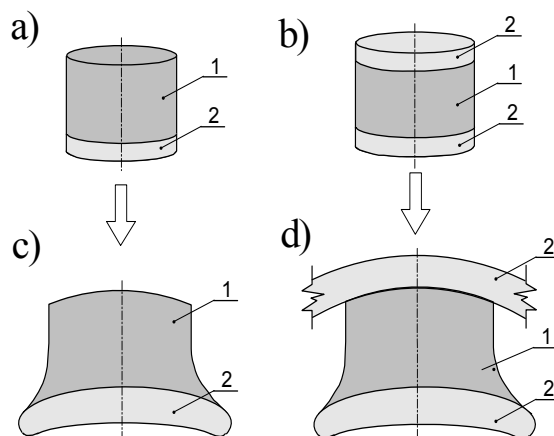

Fig. 3. Integrated samples: a-composed of 2 elements, b-composed of 3 elements; real equivalents of samples - cores of dc machine stator: c-pole with pole shoes; d-pole with pole shoes and part of yoke; 1-hard magnetic element, 2-soft magnetic element

Integrated magnetic cores are anisotropic materials for magnetic flux. This follows directly from the different magnetic properties of the magnetic core components. It is assumed that the magnetic core made from the simply dielectromagnetic is isotropic.

So when considering the use of soft magnetic composites [2, 3] is important assumed spatial isotropy of magnetic cores made from them.

Soft magnetic core in which the magnetic isotropy is fully desirable and used is a magnetic core of linear motor [1]. This kind of cores are very difficult to be optimally made of electrical sheets, but may be done of dielectromagnetics without any essential problems. Solutions of such cores may be in form of disks (Fig. 4).

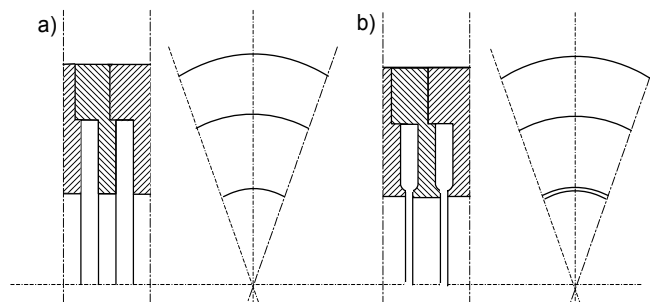

Fig. 4. Parts of the armature core (inductor) of asynchronous linear motor made of dielectromagnetics disks: a) open slots, b) half-shut slots

Rotational field in dielectromagnetic

Currently test equipment allows to study the distribution of the magnetic rotational field. If this field is a circular with a fixed value of the magnetic field induction that any changes of the magnetic field strength will be related to the anisotropy of this magnetic core. Analyzing the course of this changes it is possible thus the confirm by measuring magnetic isotropy of dielectromagnetic taken by theory so far. It is also possible to designate thus artificially produced dielectromagnetic anisotropy.

The sample of dielectromagnetic for test is made of a ferromagnetic iron powder ATOMET EM-1 produced specifically for soft magnetic cores by the Canadian

company in Quebec Metal Powders Limited. Due to the type of measurement (circular rotational field), the sample is a circular 60 mm diameter patch. Because the molding before cured has a low mechanical strength, the thickness of the sample must be relatively large and is approximately 4 mm. The pressing pressure was 800 MPa and the cure was performed at 180°C for 0.5 hours. This temperature allowed receive optimum material resistivity.

Figure 5 shows the dependence of electrical resistivity on processing heat treatment temperature of dielectromagnetic given by the manufacturer of powder [5]. This dependence of the resistivity demonstrates the application of the epoxy resin as an insulator and adhesive. It is clear why the curing temperature is so important and why it cannot be, in the case of a particular insulator, too high. Higher processing temperature gives the higher mechanical dielectromagnetic strength. The optimum curing temperature is 180°C. Mechanical strength of dielectromagnetic is enough, and its resistivity, affecting directly the reduction of eddy currents, is still relatively large.

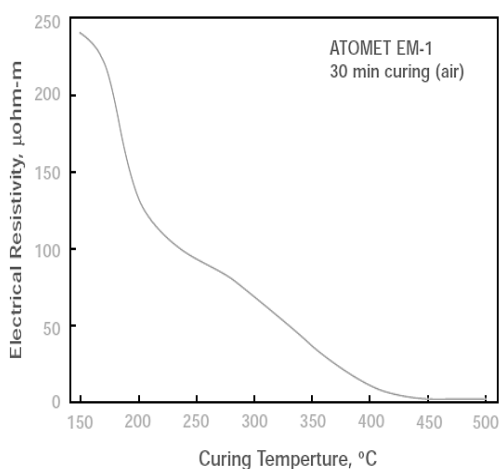

Fig. 5. Dependence the electrical resistivity of dielectromagnetic on heat treatment temperature [5]

The increase of the curing temperature only about 40°C leads to almost twice resistivity reduction. This is due to degradation of the resin, the curing temperature increases and the deterioration of its insulating properties, and therefore reduce the resistivity of the material.

Increasing the mechanical strength is done so at the expense of a significant increase in loss associated with eddy currents.

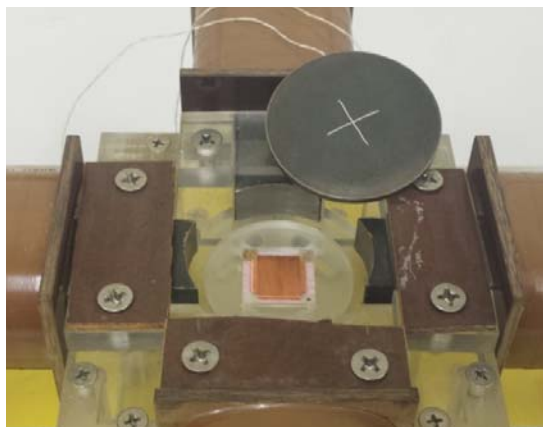

Fig. 6. Magnetic yoke, a sample with the magnetic induction measuring coils and a flat coil for direct measurement of the magnetic field strength

The measurement of the magnetic induction was carried out in the central area of the test sample, wherein the magnetization is most uniform. For this purpose, four evenly spaced holes having a diameter of 0.7 mm was performed a 10 mm distance from the center of the sample. Through these holes two measuring coils (by one coil) was made on the mutually orthogonal axes Bx and By (Fig. 6).

Research stand and results of measurements

For the measurement magnetic properties of dielectromagnetic in the alternating and rotational fields was used computer measuring system [6]. The sample was magnet on U-shaped yokes (Fig. 7) controller equipped with a permeance of both tracks magnetizing.

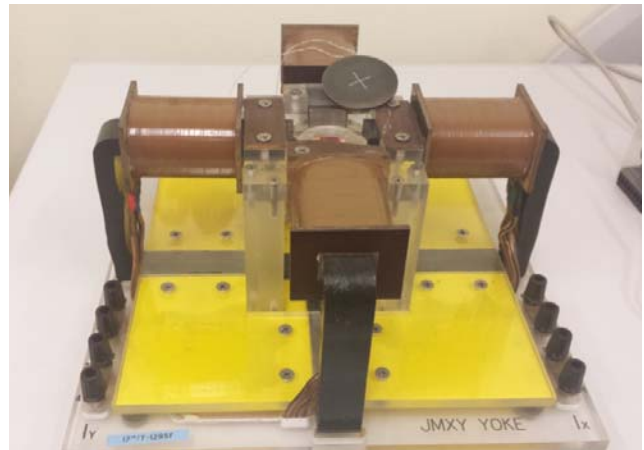

Fig. 7. U-shaped yokes for magnet the sample

Measurement of the intensity of the applied magnetic field H is carried out by direct measurement method using a flat coil located beneath the surface of the sample (Fig. 6, 7).

The system allows carrying out measurements in the alternating fields in the frequency range from 3 to 1000 Hz and a rotating field in the range of 20 to 400 Hz. Before the measurements programmed demagnetization of the sample can be possible. Measuring circular rotational magnetic field is made using linear power amplifiers suitable cores of magnetic field. The whole process of calibration and measuring procedure is fully automated.

The structural diagram of the measurement system is shown in Figure 8.

The magnetization of the sample is carried out by generation block and power amplifier. During the measuring process the corresponding signals from the test object to be served on the input amplifiers, matching them to the required levels by digital circuits. Then these signals are sampled at converters sample-and-remembering (S/H) and quantized at A/C converter switched on subsequent measurement channels through the multiplexer. The computer runs are subjected to appropriate computational procedures and in this form are displayed and stored.

In order to determine the anisotropy, the sample of dielectromagnetic put into the circular rotational magnetic field. The measurements of induction in orthogonal axes Bx and By was made by using the prepared one-coil coils.

All parameters in alternating fields were determined in both directions simultaneously.

The magnetic induction measurements were performed using a standard frequency of 50 Hz and a constant value of the intensity of magnetic field $H=7.0$ kA/m. The field strength was selected to assure that the measured induction values were located on the upward-sloping part of the actual dynamic magnetization curve $B=f(H)$ (Fig. 9).

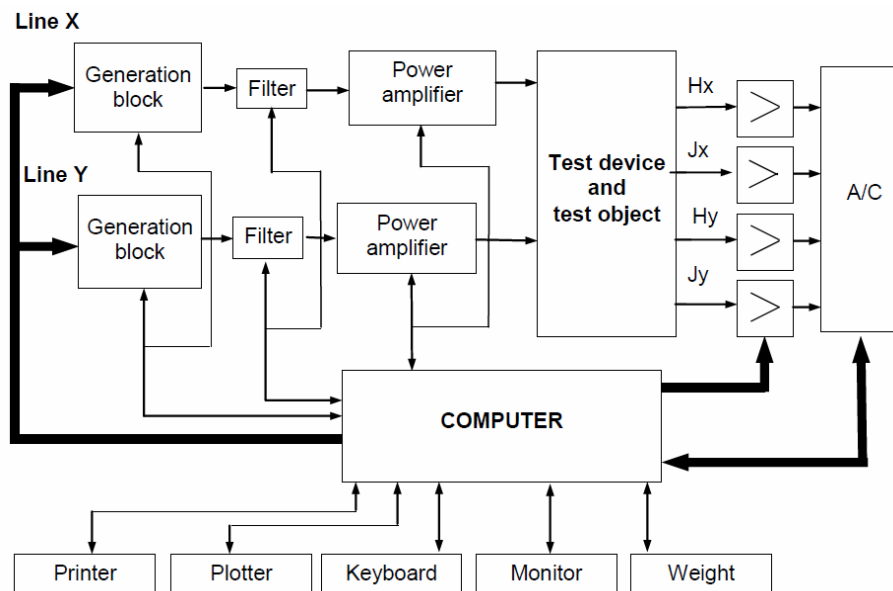

Fig. 8. The structural diagram of the measurement system

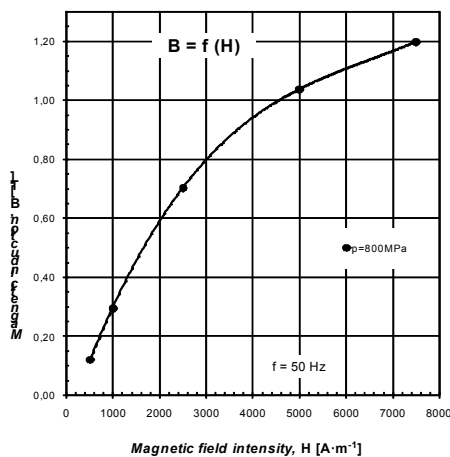

Fig. 9. Dynamic magnetization curves $B=f(H)$

The induction values induced by the circular rotational magnetic field are shown in the Figure 10. It was determined by the deviation of the induction value on the established orthogonal axes does not exceed 3%. (Fig. 10). The maximum difference between the measured induction and the mean values of all measurements is approximately 8% and is located symmetrically between the chosen axes shifted by about 17° . Those values are consisted with the calculated deviation function. This function determines the deviation between the measured points and a middle point

on the measured circle of inductions, as a function of the angle on the orthogonal axes.

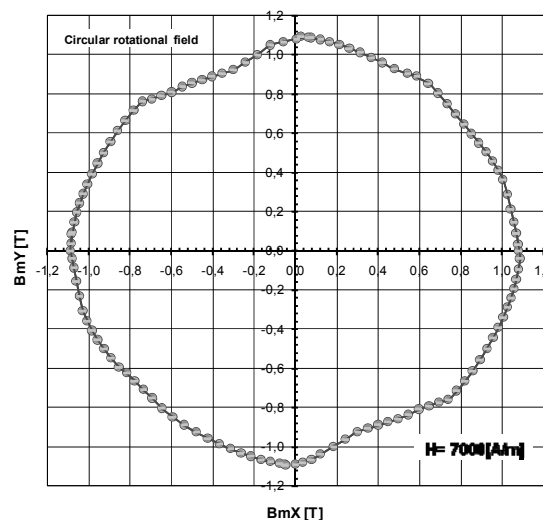

Fig. 10. Magnetic induction B distribution for a circular rotational magnetic field; $H=7.0$ [kA/m]

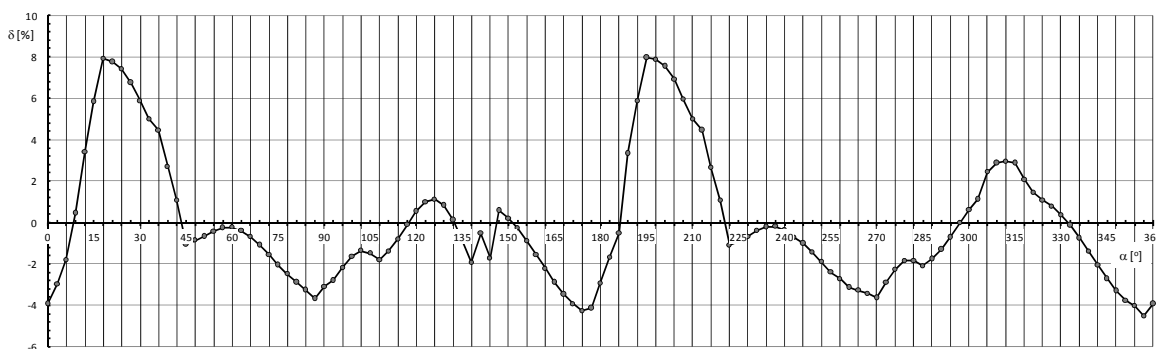

Fig. 11. Percentage difference between the measured value induction and the mean value as a function of the angle

Percentage differences between the measured induction value and the mean value as a function of the angle are presented in the Figure 11. A zero angle was adopted at the point $B_{mX}=0$, $B_{mY}=-B_{max}$ and subsequent measurements were performed in a counter-clockwise direction. The mean square deviation error takes into account all measurements points and can be taken as a parameter of the average anisotropy of the tested dielectromagnetic. In the case of the presented measurements the mean square error is 3.1%.

Summary

The measurements confirm the previously theoretically assumed isotropy of the dielectromagnetic materials.

The magnetic anisotropy amounts to less than 4.5% on the magnetic cores made from dielectromagnetics in the circular rotational field. In this case anisotropy is calculated as the quotient of the percentage difference between the maximum and minimum induction values divided by their sum. Anisotropy calculated this way is slightly larger than the anisotropy determined by the average square error (3.1%).

Disorders of spatial homogeneity of the material will be reflected in the properties measured in a circular rotational magnetic field. So it is possible not only to confirm the isotropy of the material but also to control the process from the point of view of the structure's uniformity.

This presented measuring method allows also for determination and measurement of the intentionally created, artificial magnetic anisotropy.

REFERENCES

- [1] Janta T., Kordecki A., Węgliński B., PM Soft Magnetic Composites versus Electrical Sheets, *EURO PM2000, Workshop on 'Production and Applications of Soft Magnetic Materials for Electric Motors'*, Munich, Germany, 2000, Proceedings p. 15÷29
- [2] Janta T., Perspektywy zastosowania dielektromagnetyku na magnetowód wirnika silnika asynchronicznego, *Górnictwo Odkrywkowe, Instytut Górnictwa Odkrywkowego Poltegor*, Wrocław, nr 2/2010, str. 37÷42
- [3] Hultman L.O., Jack A.G., Soft magnetic composites – motor design issues and applications, *Advances in Powder Metallurgy & Particulate Materials*, Chicago, USA, 2004, p. 194÷204,
- [4] Janta T., Weglinski B., Integrated P/M Magnetic Cores, *Studies in Applied Electromagnetics and Mechanics Volume 22, Electromagnetic Fields in Electrical Engineering ISEF'01*, Edited by A. Krawczyk and S. Wiak, IOS Press Ohmsha, ISSN 1383-7281, 2002, Netherlands, p. 430÷433
- [5] ATOMET EM-1 Ferromagnetic Composite powder, *Quebec Metal Powders Limited*, Montreal, Quebec H3A 1G1, Canada
- [6] Komputerowy system pomiarowy do badania dynamicznych właściwości magnetycznych kompozytów proszkowych w polach przemiennych i wirujących MAG-TD200. Instrukcja obsługi, *Zakład Aparatury Elektronicznej i Systemów Komputerowych "R&J MEASUREMENT"*

Author: dr inż. Tomasz Janta, Wrocław University of Technology, Faculty of Electrical Engineering, K3; ul. Smoluchowskiego 19, 50-372 Wrocław, Poland, e-mail: tomasz.janta@pwr.edu.pl