

Control Circuit Analysis and Conversion Calculation of Electric Switch Machine of High Speed Railway Turnout

Abstract. As a piece of important railway electrical equipment, electric switch machine changes the working direction of turnout by using motor as power and can reflect the state of turnout position. There are two important parameters in the working process of the switch machine: conversion current and force. Focusing on the new ZD (J) 9 electric switch machine used in high speed railway in China, this paper analyzed its control circuit; in order to control the conversion deviation of switch rail and nose rail, a finite element model(FEM) was established to analyze the optimized arrangement of traction points by adopting the design principle of integrated mechatronics system; it suggested that in design, 3 traction points be set for switch rail and the distance between the points be 4.8m and 5.4m; two traction points for nose rail and the distance be 3.6m.

Streszczenie. Elektryczna maszyna przełączająca jest ważnym elementem wyposażenia kolejowych systemów – rozjazdów. Dwa ważne parametry tej maszyny to prąd konwersji i siła. Bazując na nowej maszynie przełączającej ZD(J) 9 przeanalizowano obwód sterowania oraz przeprowadzono optymalizację systemu. (Analiza obwodu sterowania i obliczenia konwersji maszyny przełączającej rozjazdy w systemie kolejowym wielkiej prędkości)

Keywords: Electric switch machine of turnout, Control circuit, Conversion, Traction point.

Słowa kluczowe: maszyna przełączająca, rozjazdy, kolej dużej prędkości.

Introduction

Electric switch machine is a piece of important electrical equipment of turnout. It uses motor as power, which is transferred from the reducer to the rails, to change the working direction of turnout. When the switch rail sticks closely to the stock rail, the turnout can be locked in specified position and its state can also be reflected. Therefore, the electric switch machine has three functions: conversion, lock and presenting turnout position. It plays such a key role in running safety of high speed railway system that its quality and reliability are the important indicators to evaluate the railway modernization. According to electrical service failure statistics, the failures of the electric switch machine occupy the first [1]. With the increasing of railway traffic (transportation capability), the train speed is increased continuously, so the small power motors used for switch machine have been replaced by big ones. There are two main types of electric switch machine: DC and AC [2].

In order to improve the abilities of equipment application, maintenance and handling of site failure, this paper studied the control circuit of new electric switch machine ZD(J)9 adopted in high speed railway in China [3]. Meanwhile, in order to control the conversion deviation of switch rail and nose rail, a finite element mode is established to analyze the optimized arrangement of traction points by adopting the design principle of mechatronics system.

Conversion Operating Principle of Turnout Switch Power Broken Phase Protection Circuit

AC electric switch machine adopts 380V three-phase AC power. To prevent the motor from being burnt by power phase-failure, a phase-failure protection device DBQ (see Fig.1) is set. DBQ is composed of 3 current transformers, bridge rectifier and protective relay BHI. The first coil of 3 current transformers are connected in series with three-phase AC circuit respectively; the secondary coils are connected end to end. The electricity is transferred to BHI from the bridge rectifier. When the three-phase AC power is under normal power supply, the current transformer is in the state of magnetic saturation, and the BHI of DBQ is picked up (↑), which is one of the premises that drive the switch. When the switch conversion is over, DBQ lose power and BHI falls (↓).

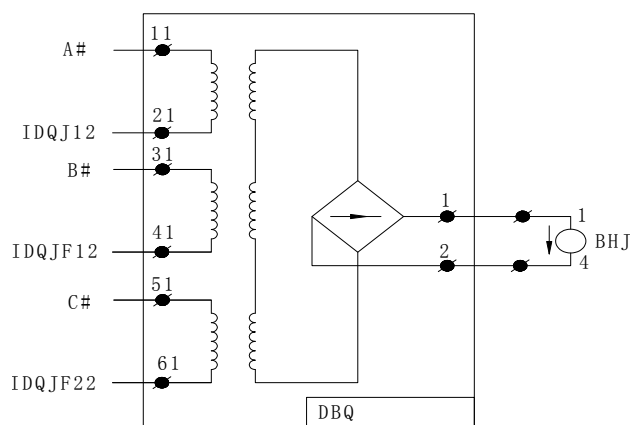

Fig.1. Simple three-phase electromotor broken phase protection circuit of turnout

The DBQ adopts the time-limited broken phase protection device BDX. If there is phase-failure for 380V AC power, the BDX will cut off the power after the BHI is picked up for 30s, and BHI falls so 1DQJ self-closing circuit(Fig.2) and the circuit of the motor are broken; then 1DQJ and 1DQJF will fall in sequence, consequently the motor stops working. This will prevent the motor from being burnt for working a long time after phase-failure [4].

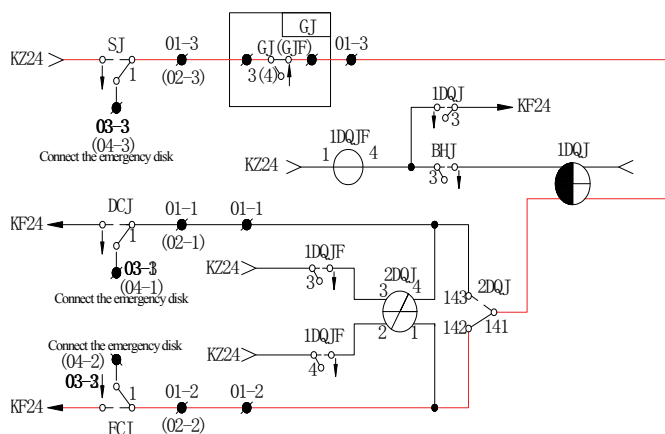

Fig.2. Start relay circuit of switch

Switch machine operation circuit

Focusing on the switch conversion from normal locking to reverse locking(Fig.2). Switch start relay circuit contains two relay circuits: 1DQJ and 2DQJ. After 1DQJ excitation circuit inspect related interlock condition, 1DQJ is picked up (slow release relay). After inspecting the picking-up condition BHJ, the self-closing circuit 1DQJ is connected. 1DQJF is picked up, and then the reverse controls relay FCJ is inspected, so 2DQJ excitation circuit is connected, and 2DQJ changes its electrode.

When 1DQJ and 1DQ J F are picked up, a three-phase AC motor circuit is formed, see Fig.3:

A Phase electric current—RD1 —DBQ A Phase current transformer terminals(11-12)—1DQJ picking up point(11-12)— X1 —motor W winding(Fig.3 red route);

B phase to motor U winding(Fig.3 blue route);

C phase current to motor V winding(Fig.3 green route).

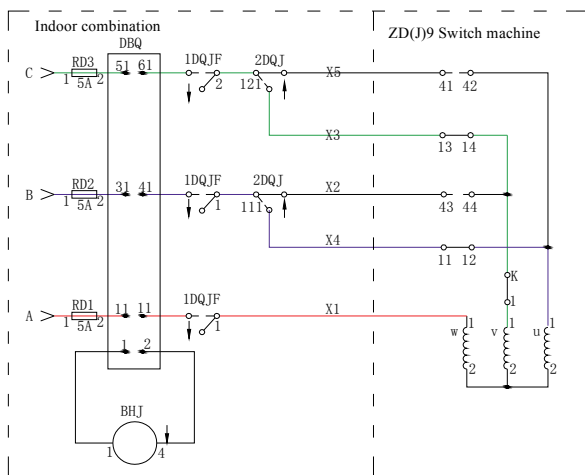

Fig.3. Three-phase AC motor circuit

In Fig.3, 2DQJ has two different positions of connecting points, so the B、C phases electric power can be changed and the motor turns forward or reversely respectively. Three-phase alternating current phase sequence is A,C,B when switch conversion from normal locking to reverse locking.

During the switch conversion from reverse locking to normal locking, the phase sequence of AC is A, B, C.

U winding circuit of motor is connected in series with a switch K, which can be switched off by hand during maintenance so as to protect the safety of the workers.

Conversion Calculation and Analysis of High Speed Railway Turnout

Switch rail conversion calculation

Based on FEM, a calculation model of switch rail conversion deviation is established. The position of tip of switch rail, turnout sleeper, traction point and jacking block are the element nodes of switch rail. The specific figure of switch rail, linear and non-linear factors during conversion are considered, and the calculation model is shown in Fig.4.

The switch rail is an Euler beam with linear cross-section, which bends only laterally in horizontal plane, without considering the influence of axial force. Lateral flexural stiffness of the switch rail is linear, and the end is 60D40 rail with uniform section [5].

Exerting a given displacement at the traction point, the pull force of each traction point is the concentrated reaction force acted to traction points.

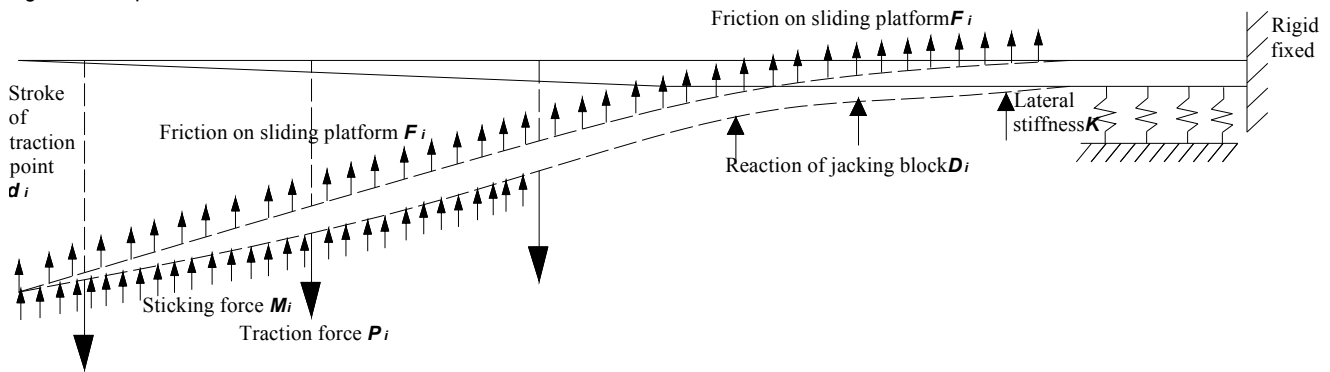

Fig.4. Calculation model of switch rail conversion

Friction force is the concentrated force acted on the sliding plate. Its direction is always the contrary to the movement of switch rail, and it is proportional to the rail weight supported by the sliding plate, not changing with the displacement of switch rail.

A non-linear spring is used to simulate the sticking force between stock rail and part of switch rail, and the contact state between jacking block and switch rail. During contact, the elastic coefficient is the lateral stiffness of stock rail or jacking block.

When the switch rail separates from stock rail, the rail will store the bending deformation energy; when it sticks to stock rail, the bending deformation energy will be released and transferred as counter resistance, which is acted to each node of the rail.

During calculation of conversion deviation, in the absence of damping the switch rail is separated from the stock rail, and then the two rails stick to each other under the damping. Comparing the positions of switch rail in two conditions, they can not overlap, and the space between two positions is the conversion deviation of switch rail.

The switch rail of No.18 turnout adopts 60D40 rail, the cross-sectional area of its tip is 54.4cm², moment of inertia in the vertical axis is 497cm⁴, the cross-sectional area of the entire section is 89.18cm², moment of inertia is 765.3cm⁴; the stock rail is 60kg/m rail, cross-sectional area 77.45cm², moment of inertia is 524cm⁴. The friction coefficient of the sliding plat is 0.25, lateral bearing stiffness of fastener is 50MN/m, the lateral stiffness of the stock rail is 30MN/m. Adopting outside locking mechanism, without considering

the conversion time difference between different traction points.

3 traction points are set on the switch rail [6], the distance between the points are 4.8m and 5.4m; their strokes are 160mm, 115mm, 65mm.

① Influence of friction coefficient

Table 1. Influence of sliding friction coefficient

Friction coefficient	$\mu=0$	$\mu=0.05$	$\mu=0.1$	$\mu=0.15$	$\mu=0.2$	$\mu=0.25$
Maximal conversion deviation(mm)	0.0	0.248	0.494	0.741	0.988	1.235
Traction force of first point	80.904	214.37	335.58	461.18	586.78	712.37
Traction force of second point	-419.67	-283.47	-134.44	8.3937	151.23	294.06
Traction force of third point	1264.4	1587.8	1892.2	2205.3	2518.5	2831.6
Total traction force	1764.974	2085.74	2362.42	2675.174	3256.91	3838.53

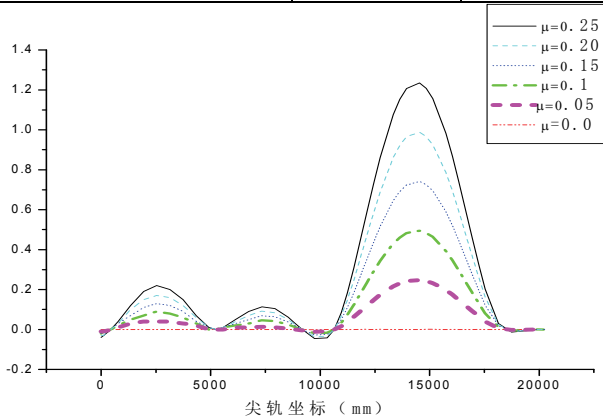

Fig.5. Relation between friction coefficient and conversion deviation

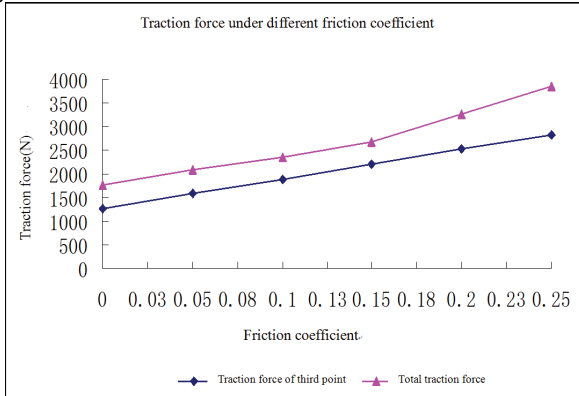

Fig.6. Relation between friction coefficient and traction force

As seen from Fig.5~Fig.6, as the friction coefficient increases, both conversion deviation and traction force increase, showing linear increasing relation; the friction coefficient of the sliding plate is the source of conversion deviation.

Table 2. Influence of different arrangement of traction points

Schemes	Space between first and second traction point/ Stroke(mm)	Space between second and third traction point/ Stroke(mm)	Max traction force (N)	Total traction force(N)	Conversion deviation (mm)	Max conversion deviation (mm)	Width of least rail groove (mm)
1	4200/120	4200/80	2650.5	3380.62	0.16	2.737	67.1
2	4200/120	4800/75	3209.7	3968.9	0.14	2.144	73.1
3	4200/120	5400/70	2667.8	3469.21	0.16	1.623	71.7
4	4200/120	6000/65	2744.9	3632.99	0.43	0.999	70.2
5	4800/115	4800/70	2730.1	3740.22	0.23	1.623	71.3
6	4800/115	5400/65	2831.6	3838.03	0.22	1.235	71.3
7	4800/115	6000/60	2976.3	4083.91	0.33	0.848	68.4

Under different friction coefficients, the traction force and conversion deviation are calculated, as seen in Tab.1 and Fig.5~Fig.6.

② Optimization of traction point arrangement

The first traction point and its stroke(160mm) is fixed, changing the positions of the second and third traction points and their strokes, and then the influence of traction point position on the conversion deviation is studied, sliding friction coefficient $\mu=0.25$, and the calculation results are shown in Tab.2. Fig.7 shows the influence of position change of the third traction point on the conversion deviation when the space between the first and second traction point is 4200mm.

As seen in Fig.7, the conversion deviation between the third point and the end of switch is big, if the third one is moved back, the conversion deviation decreases greatly, but the deviation between the second and third point will increase. Moving back the traction point appropriately is favorable to decreasing the maximal conversion deviation.

Fig.8 shows that the space between the traction point 1 and 2 is better to be 4800mm, which is more favorable to decreasing the conversion deviation. When the space between point 2 and 3 is 6m, the space between switch rail and stock rail is 0.33mm, which is unfavorable to the transfer of wheel load between the switch rail and stock rail. It is suggested that the distance between point 2 and 3 be 5.4m in design.

③ Optimization of the traction point stroke

The strokes of traction point 1 and 3 are 160mm and 65mm respectively. The change of the stroke of traction point 2 will have great influence on the traction forces of each point and little influence on the conversion deviation. If the positions of traction point 1 and 2 keep constant, the stroke difference of the traction point 3 doesn't only influence the traction force, but the conversion deviation between it and switch rail end. It is suggested that the linear design be adopted, and minimize the stroke difference while installing.

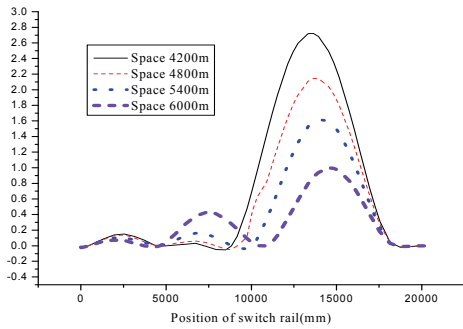

Fig.7. The conversion deviation when the space between traction point 1 and 2 is 4200mm

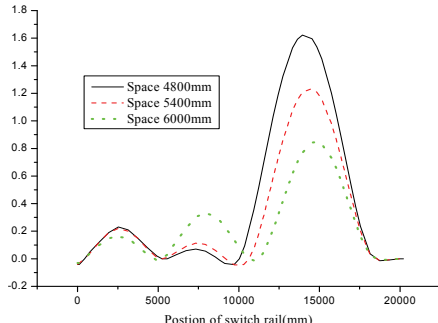

Fig.8. The conversion deviation when the distance between traction point 1 and 2 is 4800mm

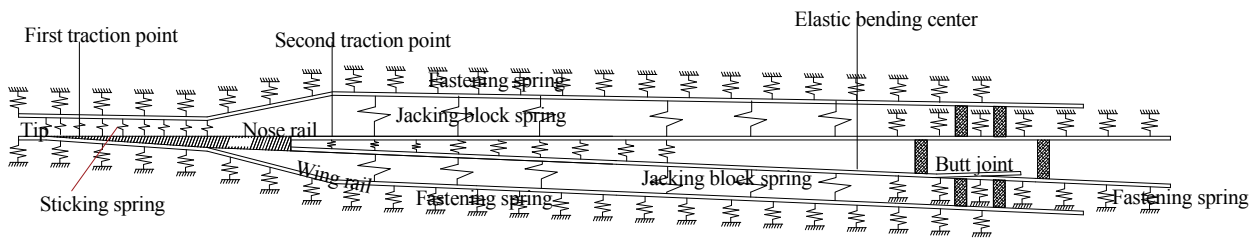

Fig.9. Conversion calculation model of single-limb bendable nose rail

The nose rail is an Euler beam with linear cross-section, which bends only laterally in horizontal plane, without considering the influence of axial force. Lateral flexural stiffness of the nose rail is linear.

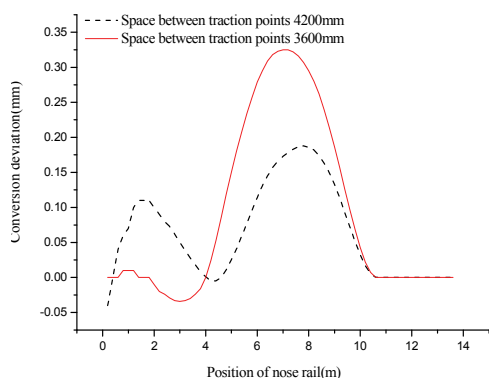

Fig.10. Conversion deviation of the nose rail (under different space between traction points)

Adopting outside locking mechanism, viewing each traction force as the concentrated force acted to the center of sleeper span; the stroke of each traction point is given value, adopting the model of solving the reaction force under given displacement; considering the friction on sliding plate. The

④ Set analysis of roller plate

Comparing the influence of different number of rollers, we consider setting three, four or more rollers. When four rollers are set, the fourth one still bears big vertical force, so another can be added to share the force. When three or four rollers are set, the conversion force and deviation both decrease greatly. More rollers are favourable to decreasing conversion force and deviation, so we suggest that 5 rollers be set evenly.

The conversion deviation of the switch rail can be constrained in allowable range when three traction points and rollers are set or only four traction points are set; the conversion deviation of the switch rail can be decreased more when four traction points are set and rollers or convex platform are added. It is more economic to set three traction points, and the space between points are 4.8 m, 5.4 m.

Nose rail conversion calculation

Conversion deviation of the nose rail is the deviation of the different parts of the turnout frog in real operation and ideal state without friction force. In calculation, pulling the nose rail to operation state when there is no friction; then pulling it back when there is friction force. The displacement difference of different parts of nose rail is the conversion deviation [7].

friction is the concentrated force acted on the sliding plate; it is proportional to the rail weight at the span and its direction is always contrary to the movement of the nose rail.

In this model, supposing all the lateral DOFs of long nose rail end is under constraint; the long and short nose rail is connected, and the tip is bolted, the back with jacking block. Supposing the two nose rails are fixed binding in this model.

Two schemes are adopted: the space between traction points are 3.6m and 4.2m. When the space is 3.6m, the traction forces of the point 1 and 2 are 1080N and 4536N respectively; when the space is 4.2m, the traction forces of the point 1 and 2 are 1269N and 5547N respectively. Fig.10 shows the conversion deviation of the nose rail in two schemes.

Moving back the second traction point of the nose rail is favorable to decreasing conversion deviation, but the traction force will increase greatly; when the space between two points is 4.2m, the traction force is close to the rated power of the electric switch machine. The conversion deviation of the nose rail is small and within the allowable value. We suggest the distance between two points be set as 3.6m in design.

Conclusions

(1) The new electric switch machine not only inherited the advantages of traditional electric switch machine, but

could satisfy the requirement of high reliability, less maintenance and long service life;

(2) According to the analysis of conversion calculation results, it is suggested that three traction points be set on the switch rail, and the spaces between the points are 4.8 m, 5.4 m.

(3) Two traction points are set on the nose rail, and the space is 3.6m.

Acknowledgment

The support of the National Natural Science Foundation of China under grant No.51078320 and No. 51008256 is gratefully acknowledged.

REFERENCES

- [1] Y.F. XU. Causes and rectification of conversion deviation of straight switch rail and stock rail in single turnout. Shanghai Railway Science and Technology, (1998)2, 27-28
- [2] W.Q. He. 6502 Electrification Centralized Circuit(Revision). Beijing: China Railway Publishing House, (2003)

- [3] W.T. Liu, F. Liu, J. Yuan. Problems and Improving Suggestions about the Control Circuit of the ZD(J) 9 Point Switch. URBAN RAPID RAIL TRANSIT,(2004), No.5, 52-54
- [4] F.Q. Yang, W.Z. Chen. Control Circuit Analysis ZD(J)9 Switch Machine. MODERN URBAN TRANSIT, (2010)3, 14-16
- [5] P. Wang. Design Theory and Practice of High Speed Railway Turnout, Southwest Jiaotong University Press, (2011)
- [6] P. WANG. Calculation and analysis of conversion force of multipoint traction turnout. Railway Standard Design, (2002)2, 23-25
- [7] X.P. CAI. C.H. LI. Study on Controlling the Switching Force and Scant Displacement of the Point Rail of the High Speed Turnout. Journal of the China Railway Society, Vol.30(2008), 48-51

Authors: *prof. dr Ping Wang, MOE Key Laboratory of High-speed Railway Engineering, Southwest Jiaotong University, Chengdu 610031, China; dr Rong Chen, MOE Key Laboratory of High-speed Railway Engineering, Southwest Jiaotong University, Chengdu 610031, China, E-mail: chenrong@home.swjtu.edu.cn.*