

Winding type influence on efficiency of an induction motor

Abstract. The article presents an analysis of the winding type influence on the efficiency of an induction motor. The aim of this work is to choose such a type of stator winding that the induction motor will have the best efficiency by employing minimum winding (copper) mass. Three types of stator windings were considered in the analysis: concentric single layer winding, concentric double layer winding and fractional concentric winding. The complete procedure for the calculation of winding data is performed. The analytical calculations of electromagnetic characteristics were performed with the software package emLook in order to select the best suited winding type and consequently ensuring the best efficiency and performance of the induction motor in question. The presented results are applicable for the industry of electric machines.

Streszczenie. Artykuł przedstawia analizę wpływu typu uzwojenia na sprawność silnika indukcyjnego. Celem pracy jest wybór takiego typu uzwojenia stojana, które zapewni maksymalną sprawność przy minimalnej masie uzwojenia. Trzy typy uzwojeń stojana zostały rozpatrzone: uzwojenie koncentryczne jednowarstwowe, dwuwarstwowe oraz uzwojenie koncentryczne ułamkowe. Przedstawiono procedurę obliczania danych uzwojenia. Do wyznaczenia charakterystyki elektromagnetycznej wykorzystano obliczenia analityczne z pakietem emLook. Wyselekcjonowano najlepszy typ uzwojenia, zapewniający najlepszą sprawność działania rozważanego silnika indukcyjnego. Przedstawione wyniki zostały implementowane w rozwiązaniach przemysłowych. (Wpływ typu uzwojenia na sprawność silnika indukcyjnego)

Keywords: induction motor, stator winding, characteristics, efficiency.

Słowa kluczowe: silnik indukcyjny, uzwojenie stojana, charakterystyka, sprawność

Introduction

Three-phase asynchronous squirrel-cage motors (induction motors) are often used in industrial applications because of their low cost, relatively simple manufacturing and robust construction. Their development started in 1885 with Galileo Ferraris who first realized the fundamental induction motor. After that, Nikola Tesla exposed the theoretical foundations for understanding the principle of operation. The most frequently used induction motor with squirrel-cage was designed by Mikhail Dolivo-Dobrovolsky, only year after the Ferraris's discovery. In all the years since the first induction motor was produced, induction motors have been developed and modified for several reasons. In the last decade according to modern energy-efficient society, the development has been oriented into the improvement of induction motor energy-efficiency.

This paper presents winding type influence on efficiency of an induction motor considering the mass of used copper.

Winding type influence on efficiency

Ordinary production of induction motors is usually based on standardized stator and rotor laminations which can be bought on the market from several lamination producers (e.g. [1]). The efficiency of induction motor depends on different factors: producer's technology (purity of squirrel-cage material), quality of bearings, quality of lamination materials, construction of housing (additional losses) and type of winding which is inserted into the stator slots. Moreover, the type of winding can have significant influence on induction motor efficiency. Therefore, the influence of three different winding types on induction motor efficiency is presented in this paper. Those different winding types are: concentric single layer winding, concentric double layer winding and fractional concentric winding. The single layer concentric winding is presented in Fig. 1. This type of winding is appropriate for machine inserting but is rarely used in mass production because greater copper mass is needed for this winding type.

The most used winding type for medium-size induction motors is a double layer winding with pitched winding step, for example pitched for two stator slots (Fig. 2). Significant advantage of the aforementioned winding is a smaller mass of inserted copper because of shortest winding-ends.

A special type of winding is the fractional concentric winding which is partially single layered and partially double layered (Fig. 3). Advantages are a smaller mass of inserted copper because of shortest winding-ends and also smaller contents of higher harmonics in the motor's magnetic field.

Description of used induction motor

This paper deals with the air-cooled motor which is designed in explosion-proof protected housing. The motor is a four pole delta-connected induction motor with 36 stator slots and 28 rotor slots. The cross-section of the used stator and rotor lamination is shown in Fig. 2. Details of the stator and rotor slot geometry are shown in Fig. 3 and in Fig. 4, respectively. Oriented nominal data of the used induction motor is presented in Tab. 1.

Table 1. Oriented nominal data of the induction motor prototype

U (V)	I (A)	P (W)	n 1/min	PF	EFF	f (Hz)
D400	8	4000	1430	>0,8	>0,8	50

Calculation of winding data

In this section the whole procedure for calculation of winding data is presented. The calculation is performed for concentric single layer winding (Fig. 1). For the other two windings used in this paper, the calculation procedure can be performed analogously. The results of winding data calculations for all winding types are presented in Table 2. The calculation of winding data starts with the calculation of number of stator slots per pole Q_p :

$$(1) \quad Q_p = \frac{Q}{2p} = \frac{36}{4} = 9$$

For designing the winding also the number of stator slots per pole and phase q is needed:

$$(2) \quad q = \frac{Q}{2pm} = \frac{36}{4 \cdot 3} = 3$$

The mechanical angle α_Q between the stator slots can be easily calculated by (3):

$$(3) \quad \alpha_Q = \frac{360^\circ}{Q} = \frac{360^\circ}{36} = 10^\circ$$

And also the electrical angle α considering the number of pole pairs p by (4):

$$(4) \quad \alpha = p \frac{360^\circ}{Q} = 2 \frac{360^\circ}{36} = 20^\circ$$

The pole-pitch τ_p can be determined with inside diameter of stator lamination D (Fig. 4):

$$(5) \quad \tau_p = \frac{D\pi}{2p} = \frac{\pi 103 \text{ mm}}{4} = 80,9 \text{ mm}$$

Regarding to Fig. 5a) the cross-section area of stator slot A_u can be calculated by (6):

$$(6) \quad A_u = (R_{1s} + R_{2s})(H_{us} - R_{2s}) + \frac{\pi R_{2s}^2}{2} = 90,32 \text{ mm}^2$$

In the initial design phase of an induction machine, the magnetic properties of iron core with maximal saturation must be defined. The oppression factor α_o for the used induction motor equals 1,441 [2] and was chosen for low saturated induction motor because of explosion-proof protected demands. The maximal air-gap magnetic flux density B_{max} in the used motor was chosen at 0,7955 T. According to [2] the average magnetic flux density \bar{B} can be calculated by (7):

$$(7) \quad \bar{B} = \frac{B_{max}}{\alpha} = \frac{0,7955}{1,441} = 0,552 \text{ (T)}$$

The magnetic flux density \bar{B} is the basic value for determination the average peak value of magnetic flux $\hat{\phi}_1$:

$$(8) \quad \hat{\phi}_1 = \bar{B} \tau_p l_{Fe} = 6,25 \cdot 10^{-3} \text{ (Vs)}$$

where l_{Fe} represents the length of stator and rotor iron package. Suppose that the induced voltage E_1 is approximately 96 % of nominal voltage, the number of turns N per phase can be calculated:

$$(9) \quad N = \frac{E_1 a}{4,44 f \hat{\phi}_1 f_w} = 288 \text{ (turns)}$$

where f is the supply frequency, f_w the winding factor and a the number of parallel branches inside the winding. The number of conductors per phase z is:

$$(10) \quad z = 2N = 2 \cdot 288 = 576 \text{ (conductors)}$$

The number of conductors per slot z_u can be determined by (11) with considering the number of phases m :

$$(11) \quad z_u = \frac{mz}{Q} = \frac{3 \cdot 576}{36} = 48 \text{ (conductors)}$$

The copper fill factor in stator slot f_{Cu} for this size of induction machine equals 0,42. In practice this factor depends on several facts: thickness of stator insulation, size of stator slot cross-section A_u and diameter of copper conductors d_{Cu} . From the aforementioned fill factor f_{Cu} and cross-section area of stator slot A_u the cross-section of copper conductor can be defined A_{Cu} :

$$(12) \quad A_{Cu} = f_{Cu} \frac{A_u}{z_u} = 0,42 \frac{90,32}{48} = 0,7903 \text{ mm}^2$$

In practice for this calculated cross-section (12), the two conductors with standard diameter $d_{Cu} = 0,71 \text{ mm}$ are used. For calculation of winding the ohmic resistance per phase R_p and copper mass M_{Cu} the (13) and (14) can be used:

$$(13) \quad R_p = \frac{\rho_{20} z l_c}{A_{Cu} a^2} = \frac{0,0175 \cdot 576 \cdot 0,272}{0,7903 \cdot 1^2} = 3,47 \text{ (\Omega)}$$

$$(14) \quad M_{Cu} = \rho A_{Cu} l_v z m = 3,31 \text{ kg}$$

where l_c is the length of one conductor, ρ_{20} the electrical resistivity of copper at temperature 20 °C and ρ the specific density mass of copper.

For the other two windings used in this paper, the calculation procedure can be performed respectively as those described from (1) to (14). Calculated values for all three are presented in Tab. 2 considering the fill factor $f_{Cu} = 0,4208$.

Comparison of results

In this paper all electromagnetic and mechanical characteristics of induction motors by using the three aforementioned winding types were calculated by software package emLook (Electrical Machines Look). EmLook is based on combination of analytical and numerical calculation procedures of electric and magnetic field inside the induction motors. All calculated results are presented in tables 3 to 5 and graphically in Fig. 6.

Tab. 3 presents results for no-load point at nominal voltage. In case of double layer winding joules power losses P_{Cu0} increase because of higher no load (magnetizing) current I_{s0} . The reason for higher magnetizing current is the lower winding factor of double layer winding. Iron power losses P_{Fe0} are for all three winding types practically the same. In calculation the friction and ventilation power losses P_{fv0} are determined with experimental measurement on prototype of induction motor.

Calculated results for nominal point ($U_N = 400 \text{ V}$, $P = 4 \text{ kW}$) are presented in Tab. 4. Comparison of results shows very small differences between particular values for different types of winding. In case of double layer winding, the current I_s and rotational speed n are greater then at other two types. On the contrary, the power factor $\cos \varphi$ is smaller because of smaller winding factor of double layer winding. It is very important to mention that values for efficiency are all most the same but in case of fractional type of winding, the efficiency is higher at smallest copper mass.

For integral analysis, the comparison of starting currents I_1 , starting torque T_1 and breakdown torque T_b must be performed. Usually, for changing the type of stator winding some limitations must be considered. In this case the electrical installation with all safety equipment (fuses) demand the same ratio of starting and nominal currents I_1 / I_s . From Tab. 5 it is evident that the induction motor with double layer winding is not applicable in practice, because of: high no load current value I_{s0} , high starting current I_1 value and low value of power factor PF .

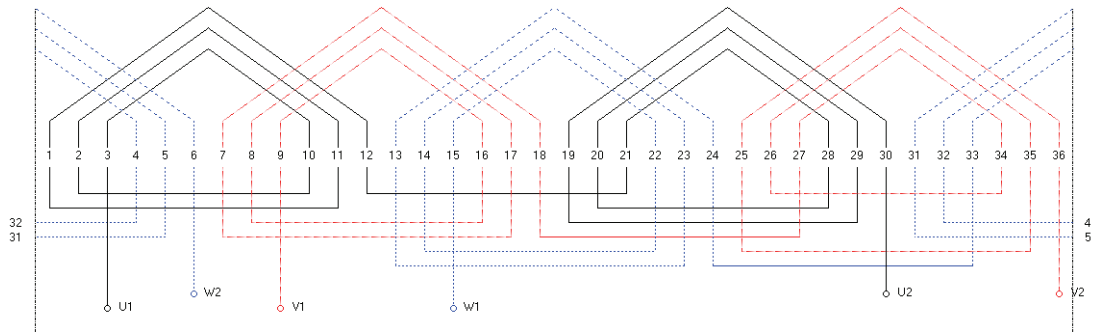

Fig.1. Concentric single layer winding in developed form presented for 36 stator slots.

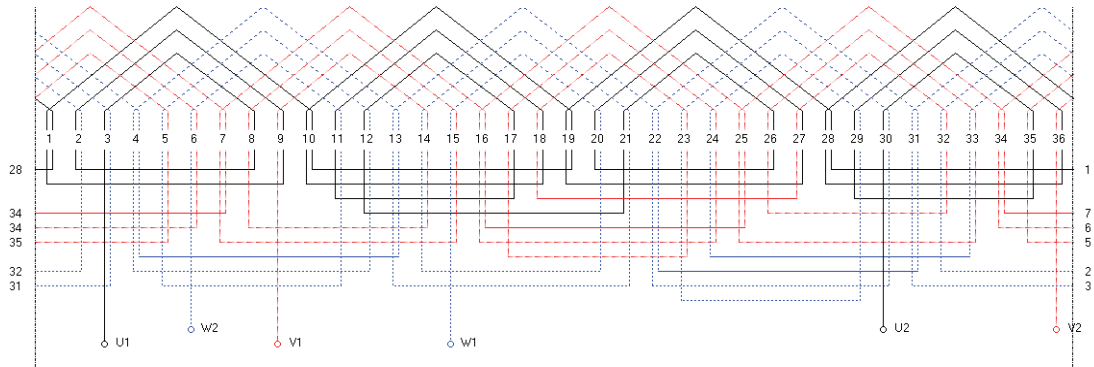

Fig.2. Concentric double layer winding in developed form, pitched for 2 of 36 stator slots.

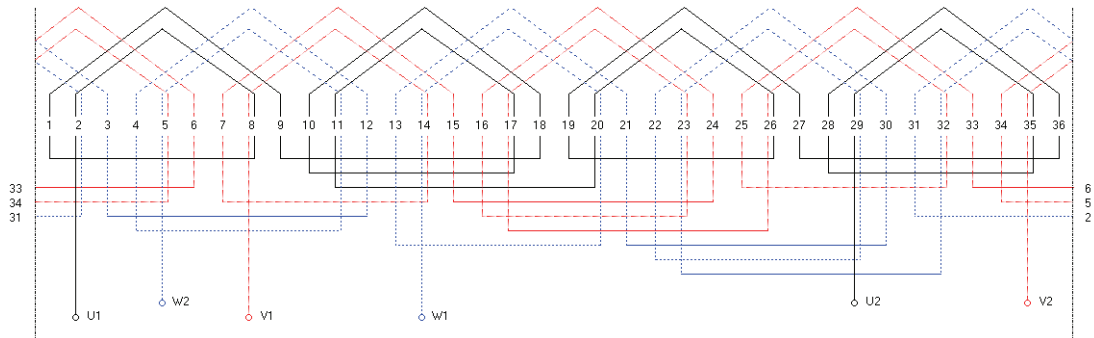

Fig.3. Fractional concentric winding in developed form, pitched for 1 of 36 stator slots.

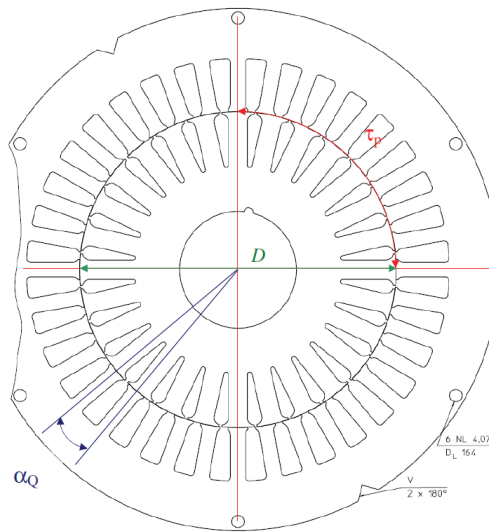

Fig.4. Cross-section of stator and rotor lamination with marked values needed for winding data calculation [1].

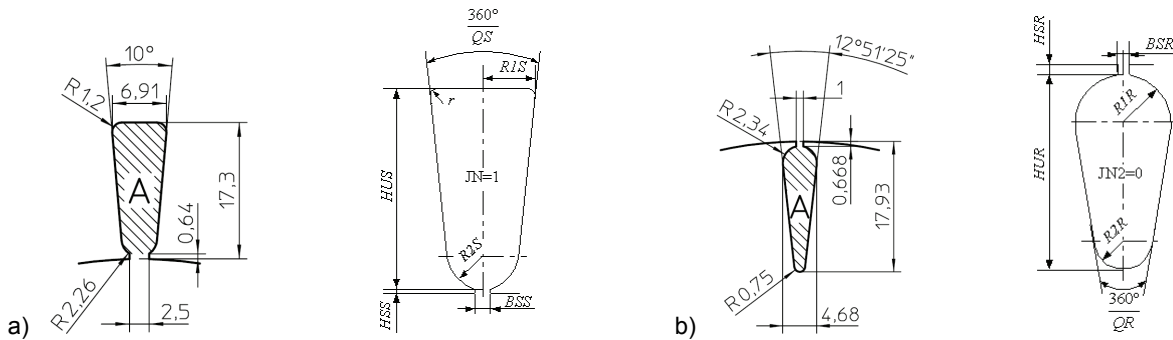

Fig.5. Cross-section of stator and rotor slot with marked dimensions [1] and values [2].

Table 2: Comparison of calculated winding data results

Winding type	Winding step	N (turns)	z (cond.)	z_u (cond.)	f_w	R_p (Ω)	M_{Cu} (kg)
Single layer	1-8,10,12	576	288	48	0,9598	3,47	3,31
Double layer	1-6,8,10	576	288	24/24	0,9019	3,27	3,12
Fractional	1-7,9	576	288	24/49	0,9460	3,35	3,19

Table 3: Comparison of calculated results for no load point at nominal voltage $U_N = 400\text{ V}$.

Winding type	Winding step	I_{s0} (A)	P_{Cu0} (W)	P_{Fe0} (W)	P_{fv0} (W)	P_0 (W)	$\cos \varphi_0$
Single layer	1-8,10,12	3,99	68,1	115,9	45	229	0,083
Double layer	1-6,8,10	5,32	114,0	128,7	45	287,7	0,078
Fractional	1-7,9	4,02	66,5	116,2	45	227,7	0,082

Table 4: Comparison of calculated results for nominal point ($U_N = 400\text{ V}$, $P = 4\text{ kW}$).

Winding type	Winding step	P_s (W)	I_s (A)	PF	n (1/min)	s (%)	η	M_{Cu} (kg)
Single layer	1-8,10,12	4688,6	8,08	0,837	1433	4,47	0,853	3,31
Double layer	1-6,8,10	4692,0	8,59	0,788	1442	3,87	0,853	3,12
Fractional	1-7,9	4676,6	8,07	0,836	1433	4,47	0,855	3,19

Table 5: Comparison of calculated results for starting and breakdown point ($U_N = 400\text{ V}$).

Winding type	Winding step	I_1 (A)	I_1 / I_s	T_1 (Nm)	T_1 / T_N	T_b (Nm)	T_b / T_N
Single layer	1-8,10,12	42,46	5,25	52,01	1,95	76,75	2,88
Double layer	1-6,8,10	55,06	6,41	77,35	2,92	99,76	3,77
Fractional	1-7,9	44,00	5,45	55,75	2,09	80,15	3,01

Conclusions

In this paper the analysis of winding type influence on efficiency of an induction motor is performed. Three types of stator windings were included in the analysis: concentric single layer winding, concentric double layer winding and fractional concentric winding. From the presented results it is evident, that by employing the fractional concentric winding the best efficiency at the minimum winding (copper) mass of the induction motor in question is achieved. The presented results are applicable for the industry of electric machines.

[2] I. Zagradišnik, B. Slemnik, Rotating electrical machines, University of Maribor, Faculty of electrical engineering and computer science, Maribor, 2005

Authors: Miralem Hadžiselimović, Bojan Štumberger, University of Maribor, Faculty of Energy Technology, Hočevarjev trg 1, 8270 Krško, Slovenia, E-mail: miralem.h@uni-mb.si; Tine Marčič, TECES, Development Centre for Electrical Machines, Pobreška cesta 20, 2000 Maribor; Ivan Zagradišnik, University of Maribor, Faculty of Electrical Engineering and Computer Science, Smetanova 17, 2000 Maribor, Slovenia.

REFERENCES

[1] Official website of company Kinle&Spiess: www.kinle-spiess.com