

# The Application of a Microcontroller based Electrofusion Welding Machine

**Abstract-** The application of a microcontroller based electrofusion welding machine has been carried out in this paper. The purpose of this paper is to check the voltage rate which the welding element needs, in a required interval. In order to make safer and better quality welding, features such as bar code reading, welding process parameters memory, the measurement of ambient temperature and internal device temperature. True RMS measurement and real time clock have been added to the system. Electrofusion welding machine, which has been designed after various tests, is thought to be cheaper than the ones on the market, to have high output voltage stability and to operate efficiently in welding electrofusion fittings.

**Streszczenie.** Przedstawiono koncepcję elektrodyfuzyjnej maszyny spawalniczej sterowanej mikrokontrolerem. Rolą sterowania jest zapewnienie dostarczania impulsów napięciowych o odpowiednim kształcie i interwale z uwzględnieniem temperatury zewnętrznej. (Zastosowanie mikrokontrolera do sterowania elektrodyfuzyjną maszyną spawalniczą)

**Keywords:** Electrofusion welding, Polyethylene, Microcontroller, True RMS.

**Słowa kluczowe:** spawanie elektrodyfuzyjne, polietylen, mikrokontroler.

## Introduction

The pipes used for transmitting liquid and gas in installation technology are required to be durable and long lasting. Plastic and metal transmission lines are used widely in gas and water transmission lines. Nevertheless with the invention of polyethylene (PE) material in 1933, thermoplastic materials began to replace these plastic and metal transmission lines [1,2]. In the modern technology, pipes made from polyethylene (PE) are used in a wide range of fields such as transmission and distribution of natural gas; drinking and potable water networks; waste water and sewage systems; agricultural irrigation; drainage projects; temporary water distribution pipelines; sports ground irrigation; fire fighting systems; telecommunication cabling systems; hazardous waste transmission; maritime and fishery; marinas; power plants; petrochemical industry; cement industry; chemical industry [3].

Installation technology is one of the most prominent fields in which PE is used. The features making transmission lines made from PE advantageous are physical life, impermeability, controlled and easy joining process, wearing, chemical resistance, fatigue, flexibility, seismic resistance, easy production, durability, hydraulic efficiency, thermal resistance. Electrofusion (EF) fittings made from PE material are also used to join PE transmission lines (Fig. 1.a).

As it can be seen in the Fig. 1.b, an EF fitting consists of PE outer surface, coil and PE inner surface. When voltage determined by the manufacturer is applied to the fitting for a time period determined by the manufacturer, PE material in the inner surface melts and fills the gaps between the pipe ends. After the cooling period determined again by the manufacturing firm, joining is realized.

Three welding methods are widely used in welding PE pipes. These are: hot plate butt welding (Butt fusion welding), hot plate coupling welding (Socket fusion welding) and EF welding [4-7]. In hot plate butt welding, the welding process is carried out with mechanical equipments prepared specifically for this process. Surfaces to be joined are pressed against the hot plate and are heated to the welding temperature at low pressure. After the hot plate is removed, pressure to the surfaces to be joined is increased and in this way joining is accomplished. When the pipes are connected to the welding apparatus welding surfaces should be parallel to each other. In hot plate butt welding, only the butt surface is machined with the help of equipment. After the pipes are machined and cleaned the

welding surfaces are checked out to be parallel. Joining pressure is maintained until the welding area cools down completely [8].

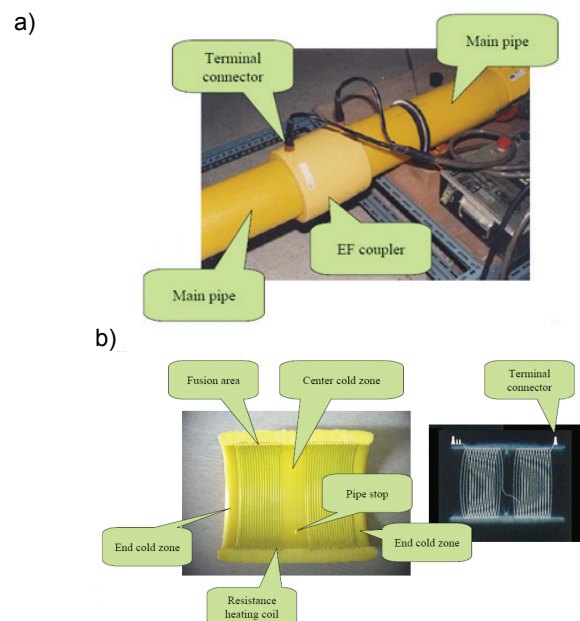

Fig. 1. a) Electrofusion fitting b) An electrofusion cross section [4].

In hot plate coupling welding, parts, the end of the pipe and the coupler are heated in a hot plate and the pipe is pushed into the coupler. After sufficient cooling, welding is completed. Particularly fittings in small diameter are used. Nowadays in in-house heating installations and clean water installations, joining process is carried out with the help of socket fusion welding technique [2;8].

Because human factor is at minimum level in joining process, electrofusion welding is a safe method with a minimum margin of error. In electrofusion welding, first of all the polyethylene pipes are cleaned up and prepared for welding, for a perfect welding process. Then joining of the pipe or pipes is carried out with EF fitting element and welding process begins by applying the energy determined by the firm. This method is the mostly preferred one because it minimizes human errors [8].

In the first examples of EF welding machines a transformer with several different secondary phases were used. In such kind of welding machines the period is determined by the user and the voltage fluctuations in the mains affects welding parameters and these are the primary disadvantages of this type. In the systems developed later voltage necessary for the EF fitting was provided by changing the triggering angle of a thyristor. With the timing elements added to the system the timing problem was also solved. Nevertheless in these systems the voltage produced, could not be measured continuously and the adjustments necessary for the welding voltage could not be made and these were the problems that could not be overcome.

With the microcontroller based systems becoming widespread an improvement was accomplished in EF welding machines. In the microcontroller based system, the trigger pulse produced to control welding voltage and the timing requirement are resolved by the microcontroller. Besides the voltage applied to the EF fitting is measured and transmitted to the microcontroller and adjustments are made against the voltage fluctuations in the mains, which make this system advantageous. Thanks to the facilities offered by the microcontroller technology, EF welding machines were equipped with features such as bar code reading, temperature measurement and error report units. There are EF welding machines with different features to join EF fitting materials.

In order to realize EF welding process, there are some common features that must be found in EF welding machines. These are as follows: [9-14].

- Operating at 200-240 V-AC
- Operating at 45-55 Hz frequencies
- Adjustable output voltage with a root mean between 8-48V
- Operating at temperatures between -10°C - +50°C
- Capacity to give an output current of 80A

### The application of a microcontroller based electro fusion welder

The primary objective of the EF welding machines is to apply a constant voltage on the EF fitting during the welding process. Non reset ability of the machine during the welding process and termination of the welding unwillingly are all undesired situations. To prevent this drawback, insulating the power circuits from the control circuits is of great importance. In addition to this the welding machine should be both user friendly and manufacturer friendly.

The features of the EF welding machine designed by taking into account the common features that must be found in EF welding machines and the facilities that can be offered to users are as follows (Figure 2):

- 180-250V AC-50 Hz operating voltage
- Soft Starting
- 3,5 KW output power
- 6-48V AC regulated output voltage
- Output current up to 100 A
- Bar code label reading
- Terminating the welding process automatically in the event of current break during the welding process
- Constant output voltage thanks to the True RMS feedback
- Recording welding operations (total 1024 records)
- Connection between RS232 interface unit and computer
- Measurement of internal device temperature and the ambient temperature

- Real time clock (RTC)
- Optical insulation between power units and control units

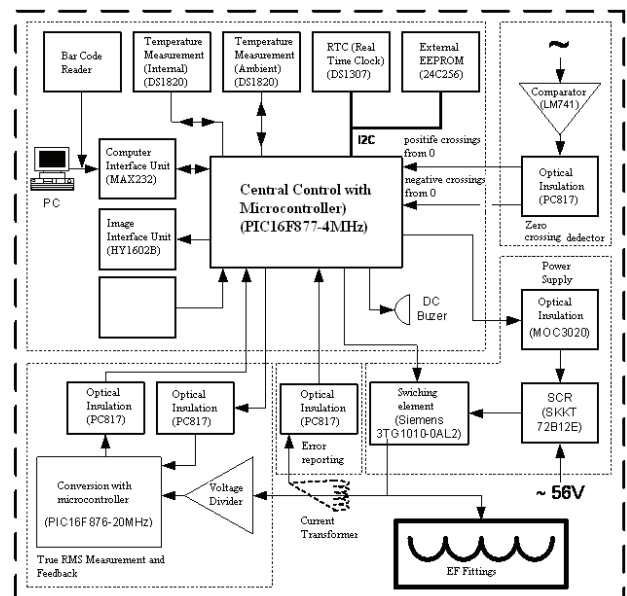

Fig. 2. Block diagram of the microcontroller based EF welding machine circuit

### Experimental results

The EF welding machine designed consists of circuit board developed for numerical and analog controls and circuit board developed for ensuring soft start process. The printed circuit boards can be seen in Fig. 3.

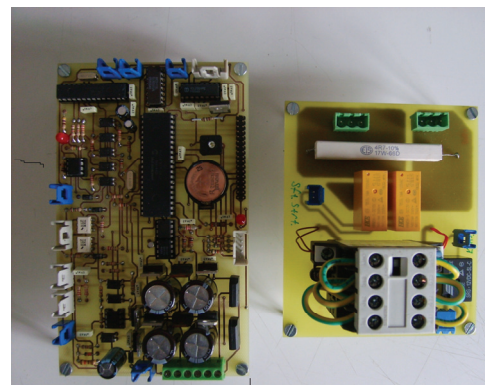

Fig. 3. Circuit boards used in EF welding machine

After the test which was carried out to make sure the units of the welding machine operate properly ended in success, a range of experimental processes were performed. The images of the running system are given in Fig. 4.

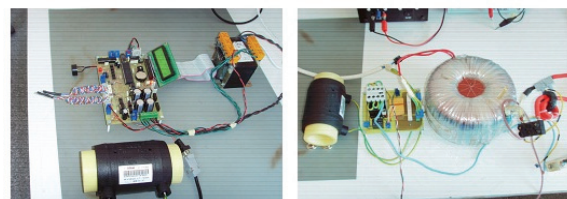

Fig. 4. Images of the running EF welding machine designed

In Fig. 5 (a), the second channel signal is the reference signal received from the network. The first channel signal is the waveform of the signal received from the output detecting the positive going zero crossings of the zero crossing detector. In Fig. 5 (b) second channel signal is the reference signal received from the network. The first channel signal is the waveform of the signal received from the output detecting the negative going zero crossings of the zero crossing detector. When the obtained output waveforms are examined it can be observed that pulses were produced at zero crossing points and these pulses were at the optimum level (digital 1, digital 0) to be used in the designed welding machine.

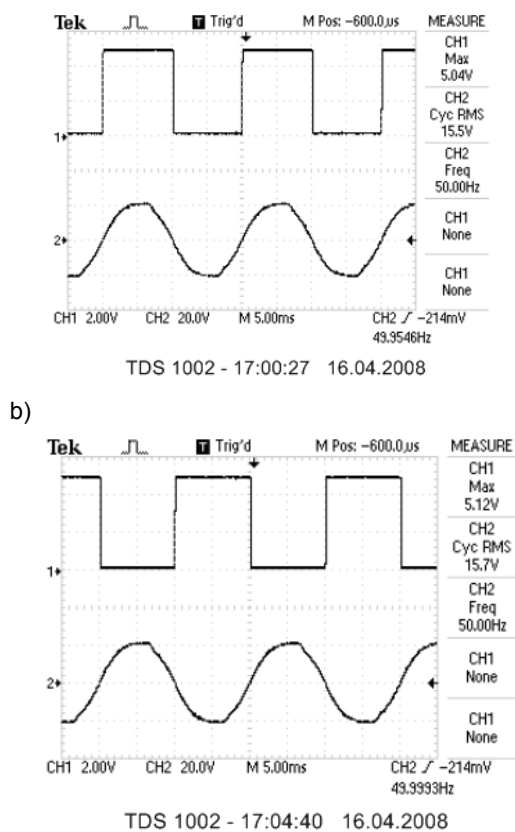

Fig. 5. Zero crossing detector waveforms (a) Positive going zero crossing signal (b) Negative going positive crossing signal

For testing the welding capacity of the designed welding machine, first of all an ohm load of 16Ω was used. After a successful result was obtained from this test, a welding process was performed with an EF fitting, which has a voltage of 35V, welding time of 1000 seconds, resistance value of 0,1Ω.

The signal taking place at the True RMS measurement unit and applied to the ADC input of PIC16F876 during the welding process can be seen in Fig. 6. In Fig. 6 the welding voltage of the first channel and the measurement signal reaching the ADC input of the second channel PIC16F876 can be observed. When the junction voltage value of 0,6V of the D3 diode in Fig. 5 is added to the voltage value obtained from the second channel, 1,93V is found as a result. This value is approximately 1/16 of the welding voltage. And this value is equal to the voltage division coefficient (the value of 16) defined in Equation (5). This proves that the voltage division coefficient in Equation (5) was selected correctly.

The value of 30,4V measured during the welding process is very close to the EF fittings weld voltage which was entered manually. This demonstrates that the triggers

necessary for the welding were produced properly, instantaneous measurement of the weld voltage was performed properly and correct instructions were sent to central control unit.

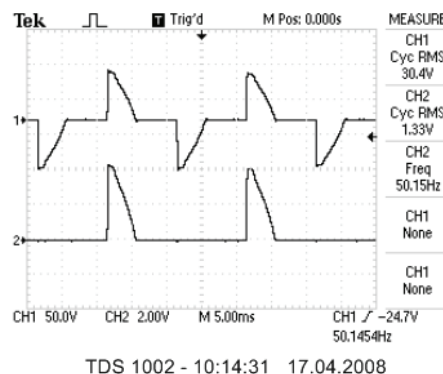

Fig. 6. Waveform reaching the ADC input of PIC16F876

One of the most desired features of the welding machines is the one which enables the production of constant weld voltage. During a welding process of 35V lasting 1000 seconds performed with the designed EF welding machine, signals received from the EF fittings are demonstrated in Fig. 7. When the first channel signals in Fig. 7 (a) and Fig. (b) are examined, it can be observed that the weld voltage of 30V is maintained at 250. and 776. seconds of the welding process. This result demonstrates that the welding machine designed produces a constant output voltage.

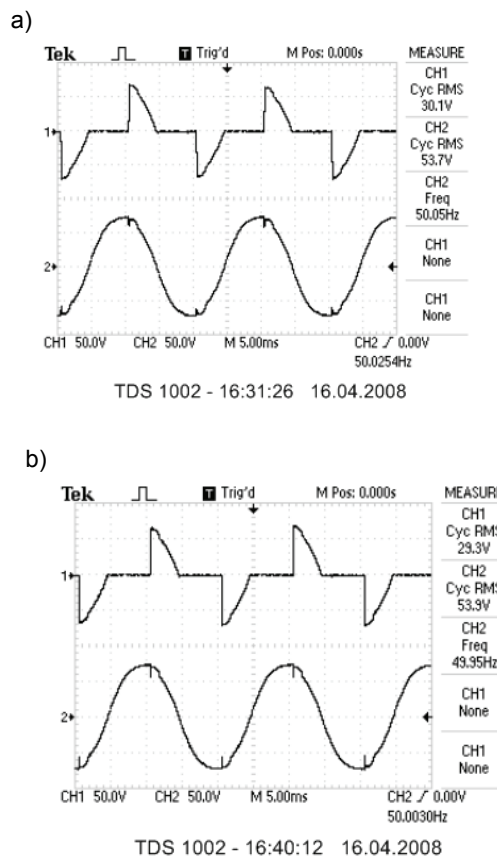

Fig. 7. Signals obtained from the EF fitting during a welding of 35V, 1000 seconds (a) Signals received at the 250. second of the welding (b) Signals received at the 776. second of the welding

## Conclusion

In this study, an application of a microcontroller based EF welding machine was performed. In this application a low-cost, user friendly welding machine capable to produce constant output voltage was produced.

With the units entailing high power consumption, the digital controls and processes were optically insulated from each other and by this way the problems of reset and bad welding were prevented. With the anticipated True RMS measurement system, measurements were performed with an error rate of 0,5%. With the feedback regarding the measured values provided to central control unit, constant output voltage was obtained. Thanks to the feature of bar code label reading, welding process performed with incorrect values entered manually was prevented. In the control of bar code reader, totally semi conductor elements were used. The welding machine was prevented from carrying out bad welding, by making temperature measurements constantly.

## REFERENCES

- [1] The Plastics Pipe Institute , Handbook of polyethylene pipe, United States, (2007).
- [2] George Fischer Inc., Plastic Piping Systems, Sweden, (1994).
- [3] Scolt D, Trademarks, Equipment Suppliers and Manufacturers, Advanced for Water Handling, ISBN: 978-1-85617-350-6, (2000).
- [4] Shin HJ, Jang YH, Kwan JR and Lee HD, Ultrasonic Array Approach for the Evaluation of Electrofusion Joints of Polyethylene Gas Piping, AIP Conference Proceedings, nr 22 (2003), 659-665, DOI: 10.1063/1.1570199.
- [5] Moore LM, Marshall GP and Allen NS, Thermal Analysis of MDPE Pipe: A Critical View, Polymer Degradation and Stability, nr 25(2-4) (1989), 161, DOI: 10.1016/S0141-3910(89)81006-7.
- [6] Bowman J, A Review of the Electrofusion Joining Process for Polyethylene Pipe System, Polymer Engineering and Science, nr 37:4 (1997), 674-691.
- [7] Shin HJ, Song SJ, Song TK, Digital Phased Array Ultrasonic Inspection System with Dynamic Focusing, 26<sup>th</sup> Review of Progress in Quantitative Nondestructive Evaluation, edited by D. O. Thompson and D. E. Chimenti, AIP Conf. Proceedings, 19A-1087-1093, (1999).
- [8] Chang DC, Chassy BM, Sounders JA and Sowers AE, Guide to Electroportion and Electrofusion. Academic Press, nr 518 (1991), ISBN-13: 978-0121680411.
- [9] <http://www.weltech.info/tr/Elektro-Fuzyon-Kaynak-Makinesi.htm#b>
- [10] <http://www.huerner.de/content/category/6/7/12/lang/en/>
- [11] <http://www.tega.com.tr/index.php?id=82,86,0,0,1,0>
- [12] [www.analog.com/UploadedFiles/Application\\_Notes/323300582AN578\\_a.pdf](http://www.analog.com/UploadedFiles/Application_Notes/323300582AN578_a.pdf)
- [13] <http://datasheets.maxim-ic.com/en/ds/DS1307.pdf>
- [14] <http://datasheets.maxim-ic.com/en/ds/DS18S20.pdf>

**Author:** *Asst.Prof.Dr. Çetin Gençer, Firat University, Faculty of Technical Education, Department of Electrical Education, 23119, Elazığ, Turkey, E-mail: cetingencer@gmail.com; Serkan Gürkan, Turkish Army Non-commissioned Officer Vocational Collage, Department of Electronic Sciences, 10100, Balıkesir, Turkey, E-mail: serkengurkan@mynet.com*